

8301 Series

ZERO AIR GENERATORS

The ACOEM Ecotech 8301 Series Zero Air Generators have been designed to supply zero air (contaminant free) to a dilution calibration system, such as the Serinus Cal 1000, 2000 and 3000.



8301LC Zero Air Generator



8301P Portable Zero Air Generator

The system comprises a compressed air source, permeation dryer and a series of optional scrubbers chosen depending on the application, producing clean, dry dilution quality 'zero air.'

The LC versions include an external Logic Control connection to activate the air source when air is required by the calibrator.

The Low Dew Point version includes a two stage membrane dryer that can provide ultra dry air at high flows. Ideal for use with Aerosol dryers used in the ACS-1000.

BENEFITS

Model 8301LC

- Available as either a 19" rack-mounted enclosure or as a portable version.
- Provides in excess of 10 slpm of zero air.

Model 8301LC-H

- A high capacity variant and provides in excess of 20 slpm.

Model 8301P

- Provides in excess of 9 lpm of zero air at a pressure of 200 kPa and is ideal for use with dilution gas calibrators.

Model 8301-H

- A high capacity Low Dew Point variant
- Provides in excess of 20 LPM at 2 bar or 200 kPa, 20 °C at ambient and sea level
- Include a low Dew Point Dryer to provide -40 °C Dew Point air at 10 lpm.

SPECIFICATIONS

Zero air flow:	0-10 l/min (std for 8301LC) 0-20 l/min (std for 8301LC-H) 0-9l/min at 200 kPa (std for 8301 P)
Protection:	Pump is thermally protected
Zero air pressure:	100-200 kPa 200 kPa (nominal for portable version)
Dew Point	- 15 °C (nominal)* (-40 °C for Low Dew Point 8301H)
Power:	220 VAC 50Hz (115 VAC 60 Hz optional)
Air scrubbers:	Air Clean-Up Canister for removal of: NO _x , NO, NO ₂ , O ₃ , SO ₂ , H ₂ S, Less < 0.1 PPB Optional: Air cleanup canister for NH ₃ or CO ₂
Size:	
8301LC & 8301LC-H:	height: 230mmH (5RU) with rubber feet width: 482mm depth: 352mm
8301P:	height: 250mm width: 280mm (including scrubber canisters) length: 565mm (including optional HCS-1000)^

* specifications are subject to environmental conditions and flow rates
^ portable version can be optioned with a HCS-1000 fitted to the end

OPTIONS

Ecotech HCS-1000 Heated CO Scrubber

- PN ECO-HCS-1000 or ECO-HCS1000-115

The HCS-1000 is designed to be used with the 8301LC/8301P Zero Air Generator to remove CO to less than 0.1 ppm and the addition of a Hopcalite® scrubber is required for background use.

Ecotech HTO-1000HC Heated Hydrocarbon/CO Scrubber

- ECO-HTO-1000HC or ECO-HTO-1000HC-115

The HTO-1000HC scrubber can be used with the 8301LC Zero Air Generator to remove CH₄, CO and light hydrocarbons to less than 20 ppb.

Ecotech External Tank Option

- PN Eo40030

Designed for use when wanting to provide a constant supply of zero air for use with FID based Hydrocarbon analysers.

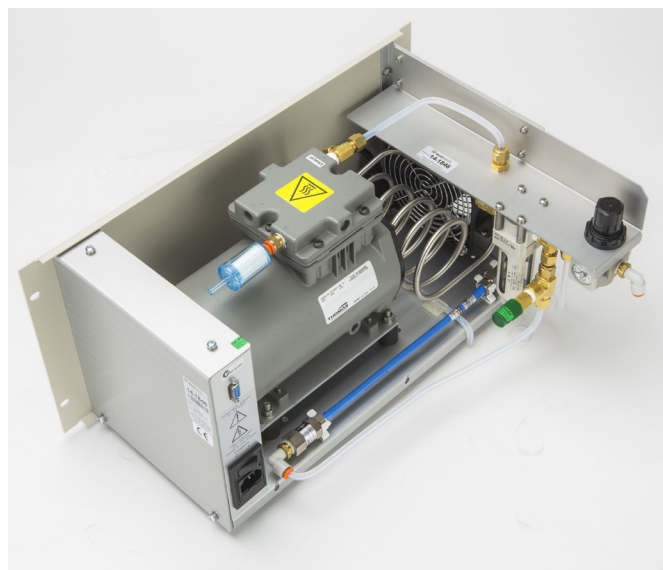

8301LC Zero Air Generator

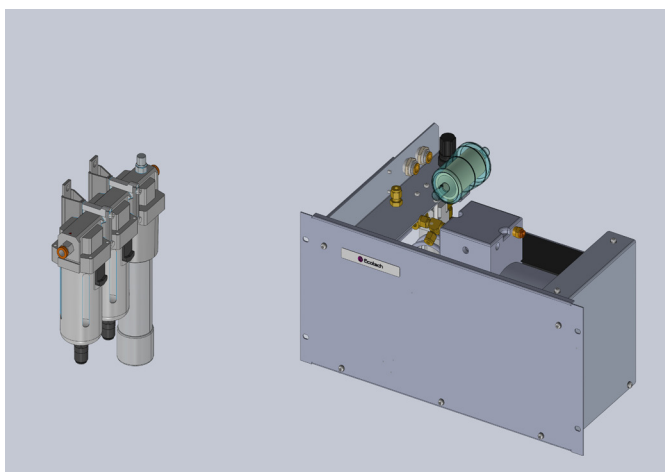

8301-H High capacity Low Dew Point variant



8301P Portable Zero Air Generator



ACOEM Ecotech

1492 Ferntree Gully Road Knoxfield VIC 3180 Melbourne Australia

+61 3 9730 7800 info.au@acoem.com ecotech.com

Specifications subject to change without notice. Ecotech, Exactus, Airodis, WinAQMS are trademarks or registered trademarks of Ecotech Pty Ltd in the United States and/or other countries. © 2020 Ecotech Pty Ltd. All rights reserved. 20201112

